



In 2015, the development team at S&S had the notion to engineer a winning flat track bike for Indian® Motorcycles. The team introduced the FTR750® race motorcycle to the tracks, raising the bar in flat track racing. By 2020, the team had won four championships and made the decision to develop larger motorcycles for the new “King of the Baggers” road-racing platform and race them for the first time in 2021. After securing several championships in these demanding races, the team still continues to push further in advancements. Through racing development, the team at S&S are excited to bring you parts inspired by the race track for your Indian Motorcycle.



SCOUT®



S I N C E 1 9 5 8



High Performance 2:1 Style exhaust system designed to make optimum power with a deep throaty exhaust note.

FEATURES AND BENEFITS

- Wake up the sound of your Scout!
- Fully shielded for optimum rider protection
- Aluminum end cap
- Stainless Steel header
- Most durable black coating available
- Does not require tuning

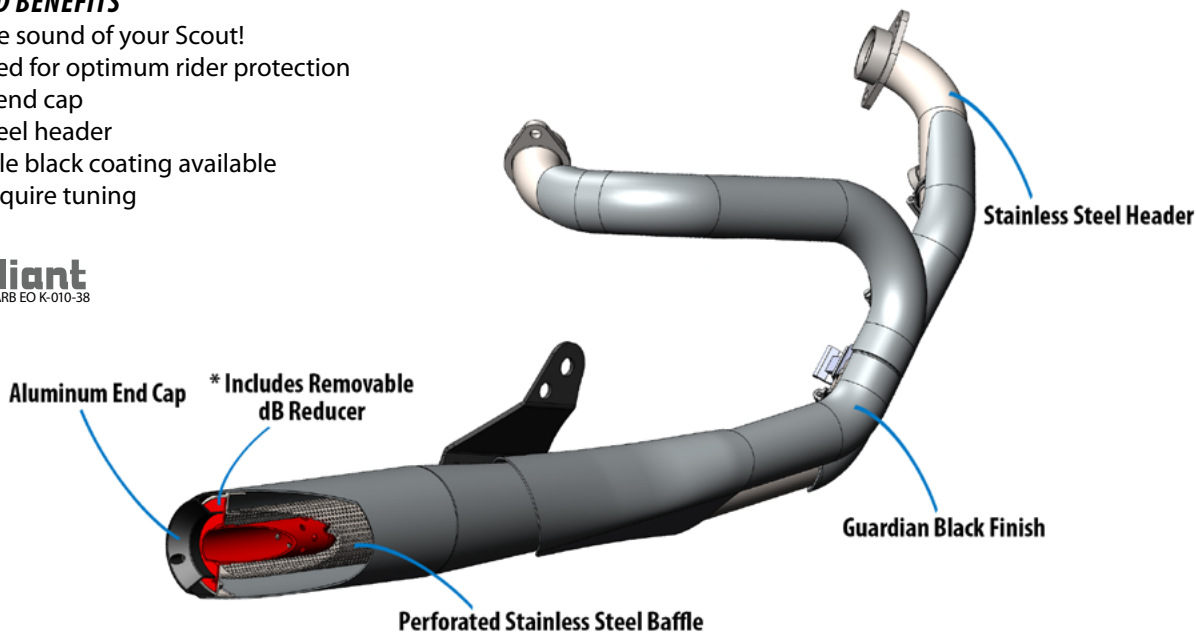

GRAND NATIONAL 2-1 EXHAUST FOR INDIAN SCOUT

WARNING This product can expose you to chemicals, including chromium, which is known to the State of California to cause cancer and birth defects or other reproductive harm. For more information go to www.P65Warnings.ca.gov

2 Into 1 Exhaust System

Grand National®



GRAND NATIONAL 2:1 EXHAUST SYSTEM FOR 2015-'23 INDIAN® SCOUT® MODELS

Description	Part #	MSRP
†Grand National 2:1 Exhaust System in Black-50 State	4111-266	\$1,499.95
**Grand National 2:1 Exhaust System in Black- Race Only	4111-266-R	\$975.95

†Exempt from emissions tampering regulations under CARB EO# K-010-38 for all 2015-2023 Indian Scout models

**FOR CLOSED COURSE COMPETITION USE ONLY. NOT INTENDED FOR STREET USE. LEGAL IN CALIFORNIA ONLY FOR RACING VEHICLES WHICH MAY NEVER BE USED, OR REGISTERED OR LICENSED FOR USE, UPON A HIGHWAY. NOT LEGAL FOR SALE OR USE NATIONWIDE ON ANY FEDERAL POLLUTION CONTROLLED MOTOR VEHICLE UNDER THE CLEAN AIR ACT.



Don't forget -
keep your bike breathing
with a new air cleaner





Performance slip-ons for the Scout that tidy up the exhaust area and produce a throaty v-twin sound. Available in chrome as well as our durable black coating, the Grand National slip-ons feature an aluminum end cap, dB reducers to tune sound levels and stainless steel baffles.

FEATURES AND BENEFITS

- Wake up the sound of your Scout!
- Aluminum end cap
- Choose between guardian black or show chrome
- Easy bolt on to the factory header
- Does not require a tuning
- Made in the USA



Perforated Stainless Steel Baffle

Aluminum End Cap

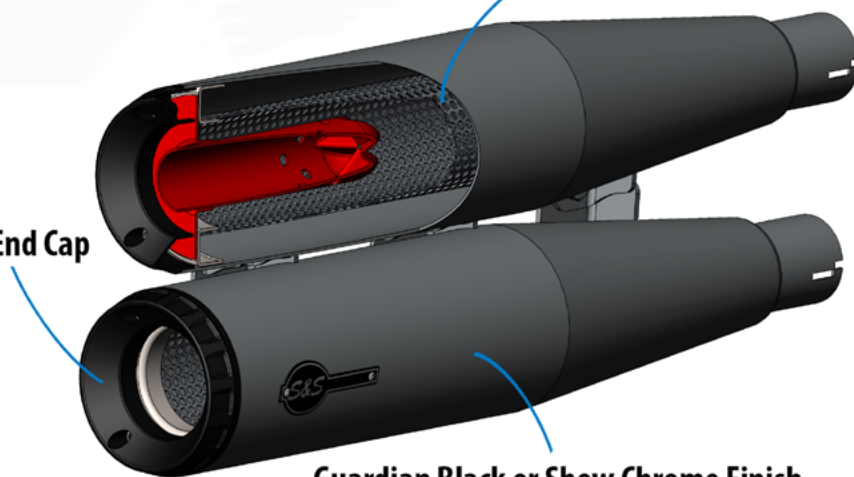

Guardian Black or Show Chrome Finish

**Don't forget -
keep your bike breathing
with a new air cleaner**



⚠️ WARNING This product can expose you to chemicals, including chromium, which is known to the State of California to cause cancer and birth defects or other reproductive harm. For more information go to www.P65Warnings.ca.gov

Slip-on Mufflers

Grand National®



GRAND NATIONAL SLIP-ONS FOR 2015-'23 INDIAN® SCOUT®

DESCRIPTION	PART NUMBER	MSRP
†Grand National Slip-Ons in Chrome - 50 State	4110-156	\$899.95
†Grand National Slip-Ons in Guardian Black - 50 State	4110-266	\$832.95
††Grand National Slip-Ons in Chrome - Race Only	4110-156-R	\$609.95
††Grand National Slip-Ons in Guardian Black - Race Only	4110-266-R	\$544.95

† Exempt from emissions tampering regulations under CARB EO# K-010-31 for all 2015-2023 Indian Scout models

††FOR CLOSED COURSE COMPETITION USE ONLY. NOT INTENDED FOR STREET USE. LEGAL IN CALIFORNIA ONLY FOR RACING VEHICLES WHICH MAY NEVER BE USED, OR REGISTERED OR LICENSED FOR USE, UPON A HIGHWAY. NOT LEGAL FOR SALE OR USE NATIONWIDE ON ANY FEDERAL POLLUTION CONTROLLED MOTOR VEHICLE UNDER THE CLEAN AIR ACT.



FITMENT

- 2015–2021 Indian Scout
- 2015–2021 Indian Scout Sixty
- 2015–2021 Indian Scout Bobber

FEATURES AND BENEFITS

- Bolt-on air cleaner assembly with high flow, washable filter media
- 127% increase in flow
- Simple one-piece construction
- Made in the USA

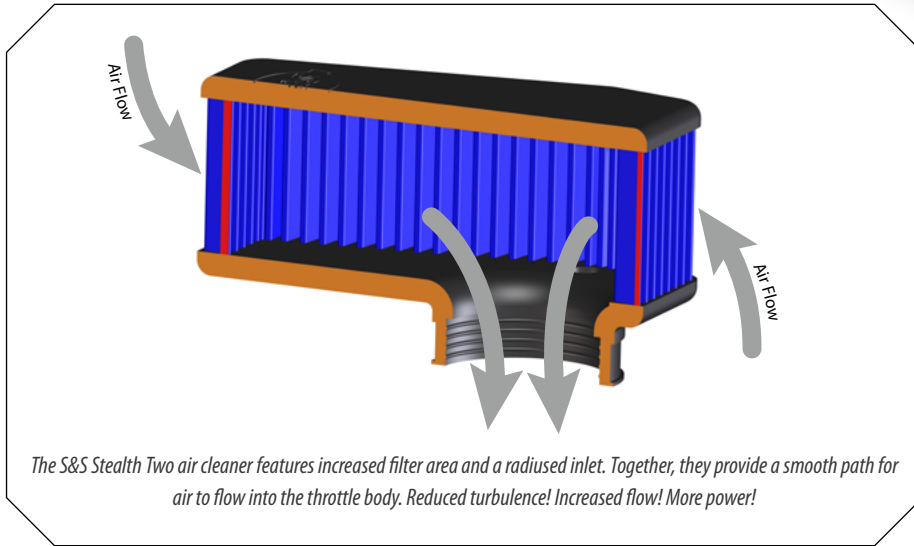

STEALTH TWO AIR CLEANER KIT

Fitment	Part #	MSRP
2015–2021 Indian® Scout®, 2015–2021 Indian® Scout® Sixty® 2015–2021 Indian® Scout® Bobber® & 2017 Victory® Octane™	170-0298E	\$193.95

Exempt from emissions tampering regulations under CARB EO# D-355-42

⚠️ WARNING This product can expose you to chemicals, including chromium, which is known to the State of California to cause cancer and birth defects or other reproductive harm. For more information go to www.P65Warnings.ca.gov

FTR 1200®



S I N C E 1 9 5 8



FEATURES AND BENEFITS

- S&S domination of American Flat Track series championship now available for FTR 1200
- True race replica system has same 3.5" can and Grand National end cap design styling as mighty FTR 750 racers
- 50 State legal version (550-0950B)! CARB EO# K-010-18
- Features S&S engineered high flow catalytic converters that bring legal performance to the street!
- Header and muffler heat shields protect rider from excessive heat
- Made in the USA!

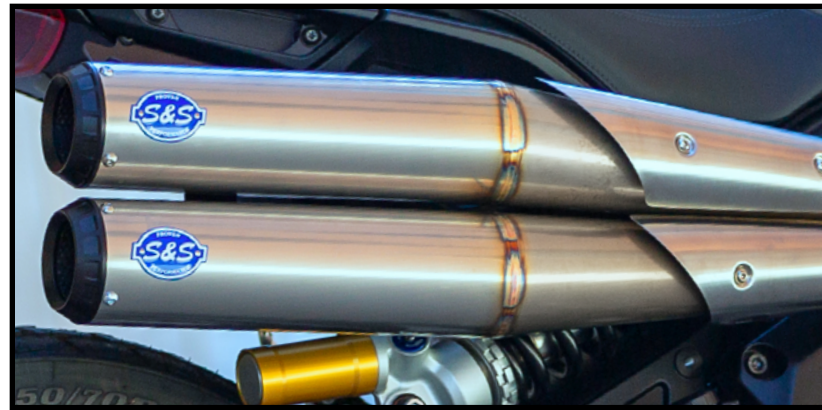

Stainless Steel perforated core baffle wrapped in fiberglass for a stealthy exhaust note

High Flow Cats Bring Legal Performance to the Street

Race style Grand National end cap design

Multi Layer Heat Shields including 6MM Ceramic Thermal Barrier to Protect Rider from exhaust heat

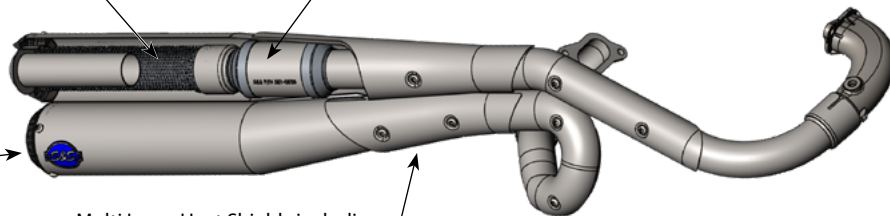

GRAND NATIONAL® 2-2 HIGH FOR 2019-2022 INDIAN® FTR 1200® — STREET LEGAL

Description	Part Number	MSRP
Stainless Steel 50 state	550-0950B	\$1,799.95
Stainless Steel Race Only	550-0949	\$1,199.95

Exempt from emissions tampering regulations under CARB EO# K-010-28 for all 2019-2022 Indian FTR 1200 Models

⚠ WARNING This product can expose you to chemicals, including chromium, which is known to the State of California to cause cancer and birth defects or other reproductive harm. For more information go to www.P65Warnings.ca.gov"

Slip-on Muffler

Grand National®



FEATURES AND BENEFITS

- Stainless steel can with exposed tig welds for factory race styling
- Carbon fiber heat shield
- Race inspired Grand National end cap
- Removable dB reducer
- Made in USA!
- EC compliant model available

Race style Grand National end cap design

Carbon fiber heat shield covers outlet from stock cat box

Stainless Steel perforated core baffle wrapped in fiberglass for a stealthy deep tone

dB reducer

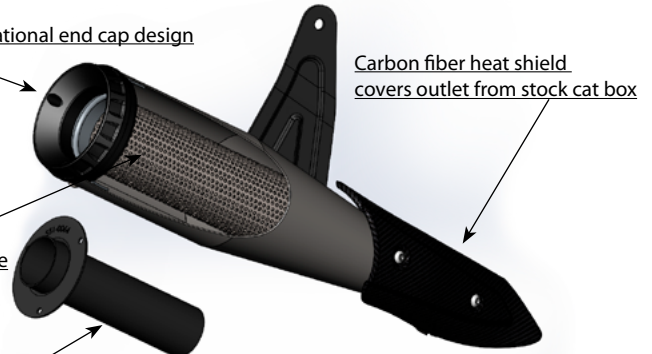

GRAND NATIONAL® SLIP-ON FOR 2019–2023 INDIAN® FTR 1200®

Description	Part Number	MSRP
Stainless Steel	550-0854	\$504.95
Stainless Steel European Market Model	550-0962	\$549.95

*Qualified manufacturer declared U.S. 50-State legal emissions replacement part on all MY 2019–2023 FTR1200 models

⚠️ WARNING This product can expose you to chemicals, including chromium, which is known to the State of California to cause cancer and birth defects or other reproductive harm. For more information go to www.P65Warnings.ca.gov

Unlock the hidden modes on your Indian FTR 1200 and FTR Rally. These models ship with Rain and Sport modes and the S&S Cycle Engine Control Manager allows you to access them with the simple push of a button.

FEATURES AND BENEFITS

- Plug & play installation
- Three ride modes
- Handlebar mount for convenient access
- Ride mode selected illuminates for visibility



SEE OUR INSTALL VIDEO HERE:

<https://www.sscycle.com/feature/indian-motorcycles/engine-control-manager-installation>



RAIN

Smoothed throttle response to help keep you in control in wet conditions.

SPORT

Maximum throttle response and aggressive power delivery. Sport mode puts you in control of all of the fun.



STANDARD

Well balanced throttle response helps you enjoy the power but keep it under control.



ENGINE CONTROL MANAGER FOR 2019-'20 INDIAN® FTR 1200® & FTR RALLY

Description	Part #	MSRP
Engine Control Manager	570-0017A	\$244.95

EXEMPT FROM EMISSIONS TAMPERING REGULATIONS UNDER CARB EO# D-355-36

⚠ WARNING This product can expose you to chemicals, including chromium, which is known to the State of California to cause cancer and birth defects or other reproductive harm. For more information go to www.P65Warnings.ca.gov

Indian[®] Touring Models



Indian® Touring Models

Qualifier 2 into 1 for 2020-2023 Indian Challenger and Pursuit



Performance baggers are a passion of ours that we take very seriously so we created our race-inspired 2:1 Qualifier exhaust in our commitment to true performance. It begins with a Stainless steel stepped header construction to maximize flow and a merged collector specifically engineered to prevent exhaust gas reversion and wraps up with a 4" full stainless muffler. The Qualifier will take your bagger to the next level by offering big power and sound, excellent cornering clearance, and championship-winning looks. Available in brushed stainless or Guardian Black finishes.



⚠️ WARNING This product can expose you to chemicals, including chromium, which is known to the State of California to cause cancer and birth defects or other reproductive harm. For more information go to www.P65Warnings.ca.gov

Qualifier 2 into 1 for 2020-2023 Indian Challenger and Pursuit

FEATURES AND BENEFITS

Brushed Stainless or Guardian Black

- Show quality Brushed Stainless or Guardian Black
- Full heat shields on both front and rear headers
- Stainless steel stepped header construction
- Includes bag support for left side saddlebag
- Includes dB reducer sound insert
- 50 State legal
- Made in USA



QUALIFIER 2:1 EXHAUST SYSTEM FOR 2020-2023 INDIAN® CHALLENGER® AND PURSUIT® MODELS

Description	Part #	MSRP
†Exhaust System, Kit, 50 State, Qualifier, 2 into 1, Brushed Stainless, Indian® Challenger, Pursuit	550-1083	\$1,599.95
††Exhaust System, Kit, Qualifier, 2 into 1, Race Only, Brushed Stainless, Indian® Challenger, Pursuit	550-1082	\$1,299.95
†Exhaust System, Kit, 50 State, Qualifier, 2 into 1, Black, Indian® Challenger, Pursuit	550-1085	\$1,599.95
††Exhaust System, Kit, Qualifier, 2 into 1, Race Only, Black, Indian® Challenger, Pursuit	550-1084	\$1,299.95

†Exempt from emissions tampering regulations on all 2020-2023 Indian Challenger models under CARB EO# K-010-37

††DISCLAIMER: FOR CLOSED COURSE COMPETITION USE ONLY. NOT INTENDED FOR STREET USE. LEGAL IN CALIFORNIA ONLY FOR RACING VEHICLES WHICH MAY NEVER BE USED, OR REGISTERED OR LICENSED FOR USE, UPON A HIGHWAY. NOT LEGAL FOR SALE OR USE NATIONWIDE ON ANY FEDERAL POLLUTION CONTROLLED MOTOR VEHICLE UNDER THE CLEAN AIR ACT.



Indian® Touring Models

Fishtail

Slip-on Mufflers



Fishtail Slip-ons from S&S are a throwback to the origins of this brand and the perfect compliment to the classic lines of Indian® touring motorcycles. Stainless baffles and aluminum tips combine to create a durable slip-on that wakes up the sound of the Indian touring machines.

FEATURES AND BENEFITS

- 4" Round Slip-On
- Fishtail End Caps
- Removable dB reducer (J2825 compliant)
- Classic Styling
- Throaty Exhaust Note
- Made in USA



Removable dB Reducer

FISHTAIL SLIP-ON MUFFLERS

DESCRIPTION	PART NUMBER	MSRP
Chrome Slip-On with Fishtail End Caps for 2014-'23 Indian® Touring Models	550-1077	\$892.95

Qualified manufacturer declared U.S. 50-State legal emissions replacement part on Indian touring models 2014-'23.

⚠ WARNING This product can expose you to chemicals, including chromium, which is known to the State of California to cause cancer and birth defects or other reproductive harm. For more information go to www.P65Warnings.ca.gov



Slip-on Mufflers

Broadhead



The Broadhead Slip-Ons feature slash cut end caps, creating a clean, traditional look while providing that ground pounding rumble one expects from S&S Cycle.

FEATURES AND BENEFITS

- 4" Round Slip-On
- Slashcut End Caps
- Sleek touring look with classic Indian styling
- Removable dB reducer (J2825 compliant)
- Made in the USA



Removable dB Reducer

BROADHEAD SLIP-ON MUFFLERS

DESCRIPTION	PART NUMBER	MSRP
Black Broadhead Slip-On with Slashcut End Caps for 2014-'23 Indian Touring Models	550-1075	\$782.95
Chrome Broadhead Slip-On with Slashcut End Caps for 2014-'23 Indian Touring Models	550-1076	\$782.95

Qualified manufacturer declared U.S. 50-State legal emissions replacement part on Indian Challenger and Chieftain models 2014-'23.

WARNING This product can expose you to chemicals, including chromium, which is known to the State of California to cause cancer and birth defects or other reproductive harm. For more information go to www.P65Warnings.ca.gov



Indian® Touring Models

High Flow

Air Cleaner



More air equals more power and the S&S High Flow air filter for the Indian Challenger does exactly that with the added bonus of a washable filter media meaning it will outlast ten of your stock filters.

FITMENT

- 2020-'22 Indian® Challenger® Models

FEATURES AND BENEFITS

- Bolt-on air cleaner assembly with high flow, washable filter media
- 4-Ply Air Filter Media for better filtration
- 20% increase in flow
- Simple one-piece construction
- Made in the USA



HIGH-FLOW AIR FILTER FOR INDIAN® CHALLENGER MODELS		
Fitment	Part #	MSRP
[†] 2020-'22 Indian® Challenger® Models, 4-Ply	170-0745A	\$79.95
^{††} 2020-'22 Indian® Challenger® Models, 2-Ply	170-0746	\$101.95

[†]Exempt from emissions tampering regulations under CARB EO# D-355-43
^{††}NOT LEGAL FOR SALE OR USE IN CALIFORNIA ON ANY POLLUTION CONTROLLED MOTOR VEHICLE *Qualified Manufacturer Declared 49-State Federal Emissions Compliant Part

WARNING This product can expose you to chemicals, including chromium, which is known to the State of California to cause cancer and birth defects or other reproductive harm. For more information go to www.P65Warnings.ca.gov

Air Cleaner

AIR CLEANER FILTER FOR 2014-'22 INDIAN® TOURING MODELS

Description	Part #	MSRP
Air Cleaner filter	170-0228	\$91.95



PRE-FILTER FOR 2014-'22 INDIAN® TOURING MODELS WITH THUNDERSTROKE 111 ENGINES

Description	Part #	MSRP
Pre-Filter	170-0255	\$61.95



170-0239



170-0242

AIR CLEANER COVER FOR 2014-'22 INDIAN® WITH THUNDERSTROKE 111 ENGINES

Description	Part #	MSRP
Chrome Air Cleaner With Nostalgic Script	170-0239	\$188.95
Chrome Air Cleaner With S&S® Cycle Logo	170-0242	\$188.95

REPLACEMENT PARTS



Qualifier 2:1 Exhaust System Replacement Parts

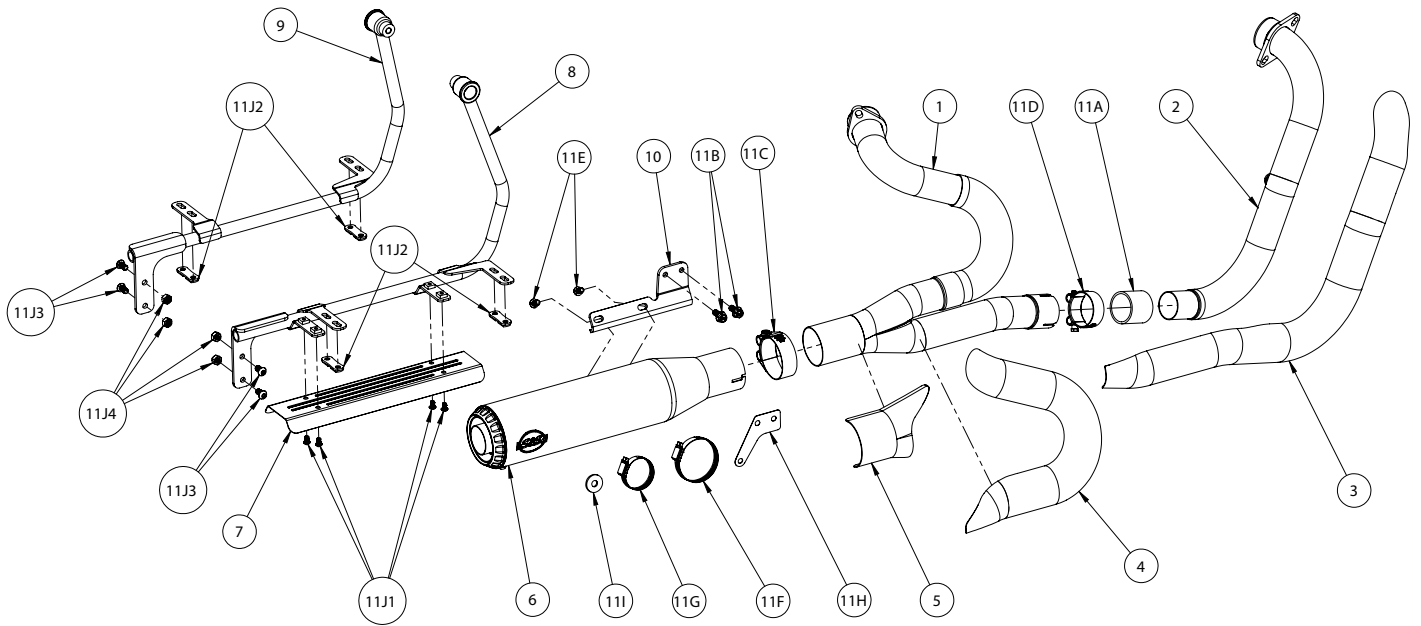

- | | |
|-------------------------------------------------------------------------------------|-----------|
| 1. Pipe, Header, 2 Into 1, Qualifier, Welded, Indian® Challenger..... | 551-1165B |
| 2. Tube, Front, Head Pipe, Qualifier, 2-1, Formed, 1.875" X .049" Wall..... | 551-1894 |
| 3. Front Shield | |
| A. Heat Shield, Front, 2 Into 1, Qualifier, Brushed, Stainless Steel | 551-1937 |
| B. Heat Shield, Front, 2 Into 1, Qualifier, Black, Stainless Steel | 551-1938 |
| 4. Rear Shield | |
| A. Heat Shield, Rear, 2 Into 1, Qualifier, Brushed, Stainless Steel..... | 551-1940 |
| B. Heat Shield, Rear, 2 Into 1, Qualifier, Black, Stainless Steel | 551-1941 |
| 5. Collector Shield | |
| A. Heat Shield, Collector, 2 Into 1, Qualifier, Brushed, Stainless Steel..... | 551-2144 |
| B. Heat Shield, Collector, 2 Into 1, Qualifier, Black, Stainless Steel | 551-2145 |
| 6. Muffler | |
| A. Muffler, Assembly, Qualifier 2-1, 49-State, 2.5" Inlet, 4" Muffler, Brushed..... | 551-2149 |
| B. Muffler, Assembly, Qualifier 2-1, 49-State, 2.5" Inlet, 4" Muffler, Black..... | 551-2150 |
| 7. Heat Shield, Saddle Bag, Qualifier, 2-1, Formed, Stainless Steel | 551-1944 |
| 8. Bracket, Assembly, Right, Bag Mount, Powdercoated..... | 551-1879 |
| 9. Bracket, Assembly, Left, Bag Mount, Powdercoated, | 551-1880 |
| 10. Bracket, Muffler, 2 Into 1, Qualifier, 2-1, Powdercoated, Black | 551-1912 |
| 11. Hardware Kit, Qualifier, 2 Into 1 | 551-1992 |
| 11A. Gasket, Muffler, 1.75" Id X 2.0" Od X 1.75" Length..... | 551-1129 |
| 11B. Screw, Hex Head, Flanged, M8 X 1.25 X 20mm, Grade 9.8..... | 500-1534 |
| 11C. Clamp, Muffler, Band Style, M8-1.25" X 60mm Bolt, 2.5" Diameter..... | 551-1272 |
| 11D. Clamp, Muffler, Band Style, M8-1.25" X 60mm Bolt, 2.5" Diameter..... | 551-1181 |
| 11E. Screw, Bhc, M8 X 1.25 X 14mm, Stainless Steel | 500-1354 |
| 11F. Clamp, Hose, Worm Drive, Sae #40 | 551-0402 |
| 11G. Clamp, Hose, Worm Drive, Sae #24 | 500-0791 |
| 11H. Template, Drill Pattern, Stock Heat Shield, 2 Into 1, Qualifier..... | 551-1993 |
| 11I. Spacer, Black, 1.125" Od X .410" Id X .125, Aluminum, 6061..... | 551-1942 |
| 11J. Hardware Kit, Bag Mount..... | 551-2126 |
| 11J1. Screw, Bhc, High Temp Lock Patch, M6 X 10mm, Stainless Steel..... | 500-1090 |
| 11J2. Plate, Nut, M6 X 1, 33mm Hole Spacing, Stainless Steel..... | 551-2113 |
| 11J3. Screw, Bhc, M8 X 16mm, Stainless Steel | 500-1189 |
| 11J4. Nut, Lock, Nylon Insert, M8 X 1.25mm X 13mm X 8mm, Stainless Steel | 500-1100 |

Broadhead Slip-ons Replacement Parts

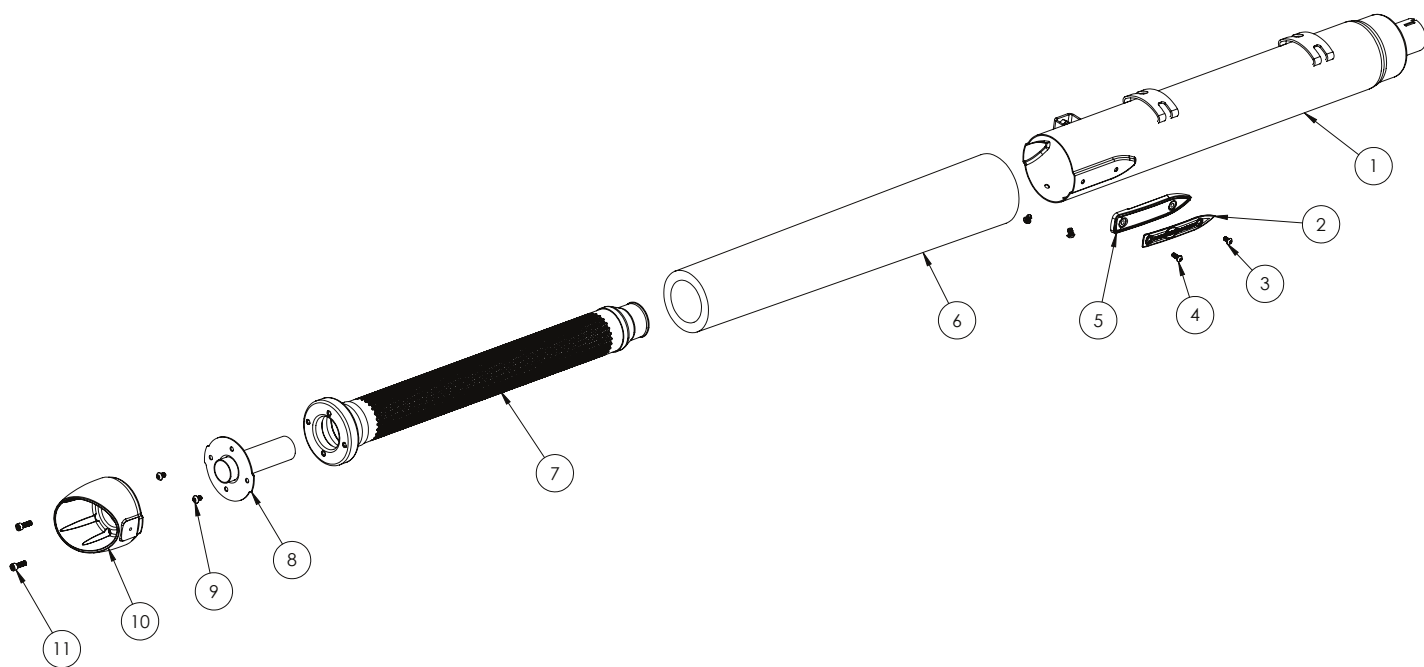

1. Muffler Assembly
 - A. Muffler, Assembly, Right, Slashcut, Black, Indian® Touring 551-0884A
 - B. Muffler, Assembly, Left, Slashcut, Black, Indian® Touring 551-0885A
 - C. Muffler, Assembly, Right, Slashcut, Chrome, Indian® Touring 551-1891
 - D. Muffler, Assembly, Left, Slashcut, Chrome, Indian® Touring 551-1892
2. Badge
 - A. Badge, Right, S&S® Logo, W/ Bolt Holes 3.82" Apart, Indian® Touring 551-1882
 - B. Badge, Left, S&S® Logo, W/ Bolt Holes 3.82" Apart, Indian® Touring 551-1883
 - C. Badge, Right, S&S® Logo, W/ Bolt Holes 3.82" Apart, Indian® Touring 551-1882
 - D. Badge, Left, S&S® Logo, W/ Bolt Holes 3.82" Apart, Indian® Touring 551-1883
3. Screw, Bhc, High Temp Lock Patch, M5 X 10mm, Polished, Stainless Steel 500-1259
4. Screw, Bhc, High Temp Lock Patch, M5 X 14mm, Polished, Stainless Steel 500-1260
5. Cap, End, Muffler, Bolt On, Powdercoated, 4", Black 551-1303
6. Insulation, Muffler, Pillow Pack, Cone Body, 24"L X 2.5" Dia Baffle 551-0798
7. Baffle, Assembly, 2020 Indian® Raptor® 551-0877a
8. Baffle, Assembly, Muffler, 4", Sae J2825, Polaris® Mustang 551-1228
9. Screw, Bhc, High Temp Lock Patch, 1/4-20 X 3/8", Stainless Steel 500-0441
10. Cap, End, Muffler, Slashcut, Powdercoated, 4", Black 551-1279
11. Screw, Shc, High Temp Lock Patch, M6 X 20mm, Stainless Steel 500-1258

Fishtail Slip-ons Replacement Parts

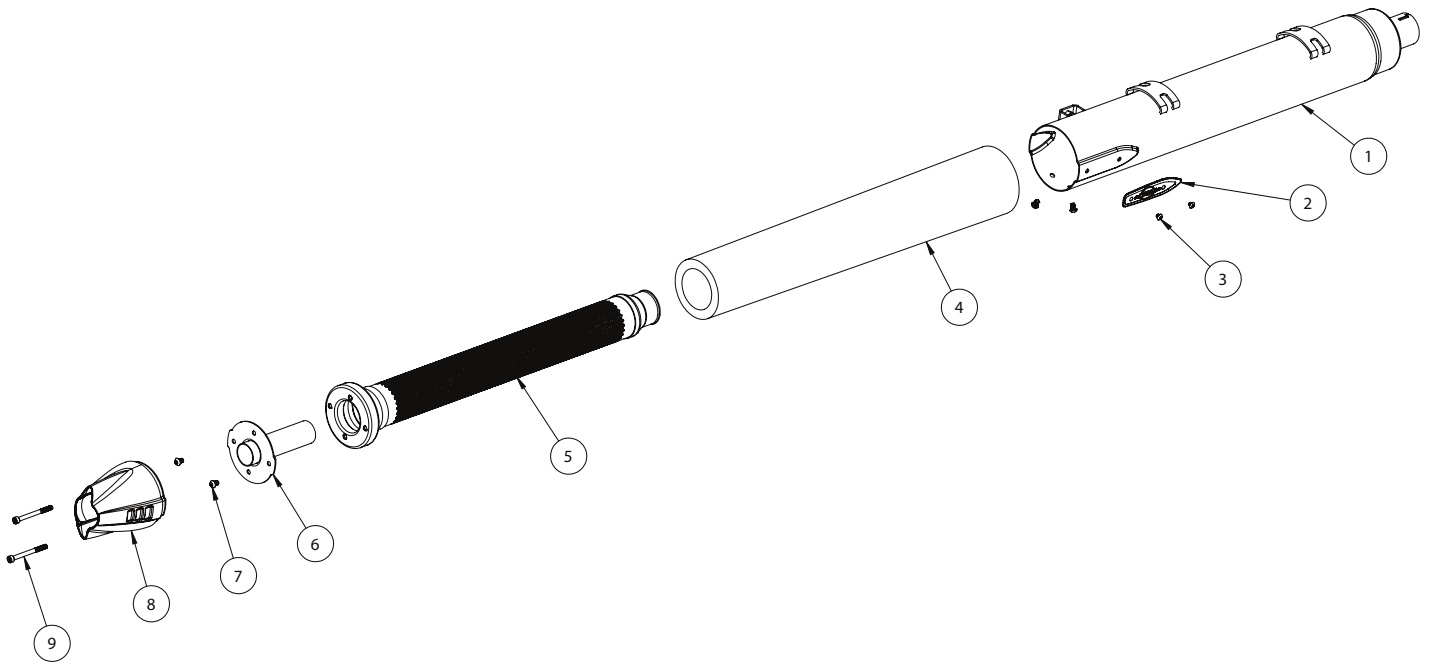

1. Shell
 - A. Shell, Right, Muffler, Outside Process, Chrome, Indian® Touring..... 551-1884
 - B. Shell, Left, Muffler, Outside Process, Chrome, Indian® Touring..... 551-1885
2. Badge
 - A. Badge, Right, S&S® Logo, W/ Bolt Holes 2.6" Apart, Indian® Touring..... 551-1884
 - B. Badge, Left, S&S® Logo, W/ Bolt Holes 2.6" Apart, Indian® Touring..... 551-1885
3. Screw, Bhc, High Temp Lock Patch, M5 X 5mm, Polished, Stainless Steel..... 500-1261
4. Insulation, Muffler, Pillow Pack, Cone Body, 24" L X 2.5" Dia Baffle..... 551-0798
5. Baffle, Assembly, 2020 Indian® Raptor® 551-0877a
6. Baffle, Assembly, Muffler, 4", Sae J2825, Polaris® Mustang 551-1228
7. Screw, BHC, High Temp Lock Patch, 1/4-20 x 3/8", Stainless Steel..... 500-0441
8. Cap, End, Muffler, Fishtail, 4", Chrome 551-1277
9. Screw, Shc, High Temp Lock Patch, M6 X 70mm, Stainless Steel 500-1257

Grand National® Slip-On Replacement Parts

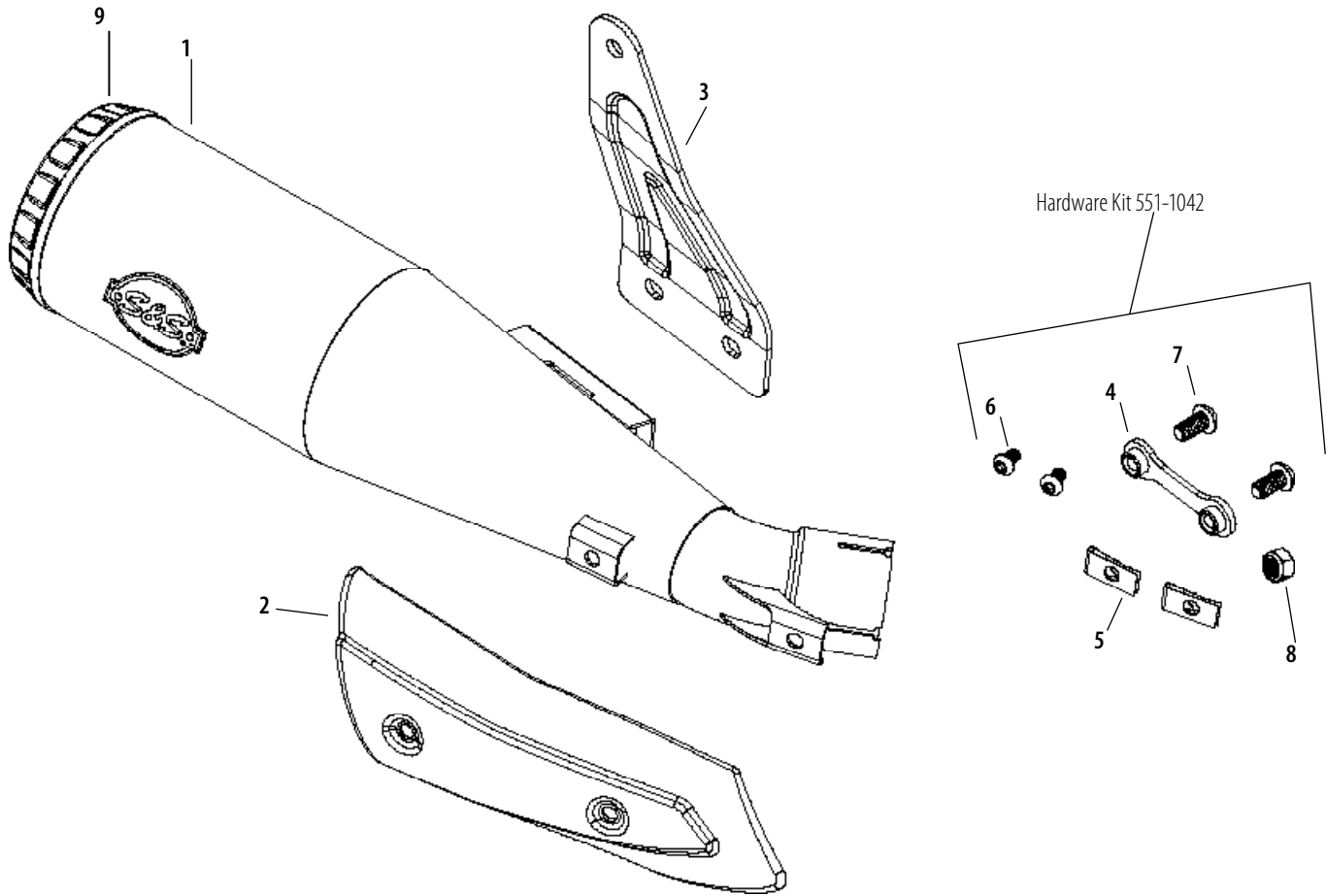

- 1. Muffler 551-1040
- 2. Heat Shield 551-0982
- 3. Bracket 551-0987

- Hardware Kit (includes 4-8 below) 551-1042
- 4. Plate, Nut, 5/16-18 x 2", Clear, Zinc 551-0469
- 5. Nut, Clip-On, 1/4-20, Zinc Plated 500-0848
- 6. Screw, BHC, 1/4-20 x 3/8", Stainless Steel 500-0846
- 7. Screw, BHC, High Temp Lock Patch, 5/16-18 x 5/8",
Stainless Steel 500-1091
- 8. Nut, Lock, Nylon Insert, M8 x 1.25mm x 13mm x 8mm,
Stainless Steel 500-1100
- 9. End cap 551-0291

2:2 High Exhaust System Replacement Parts

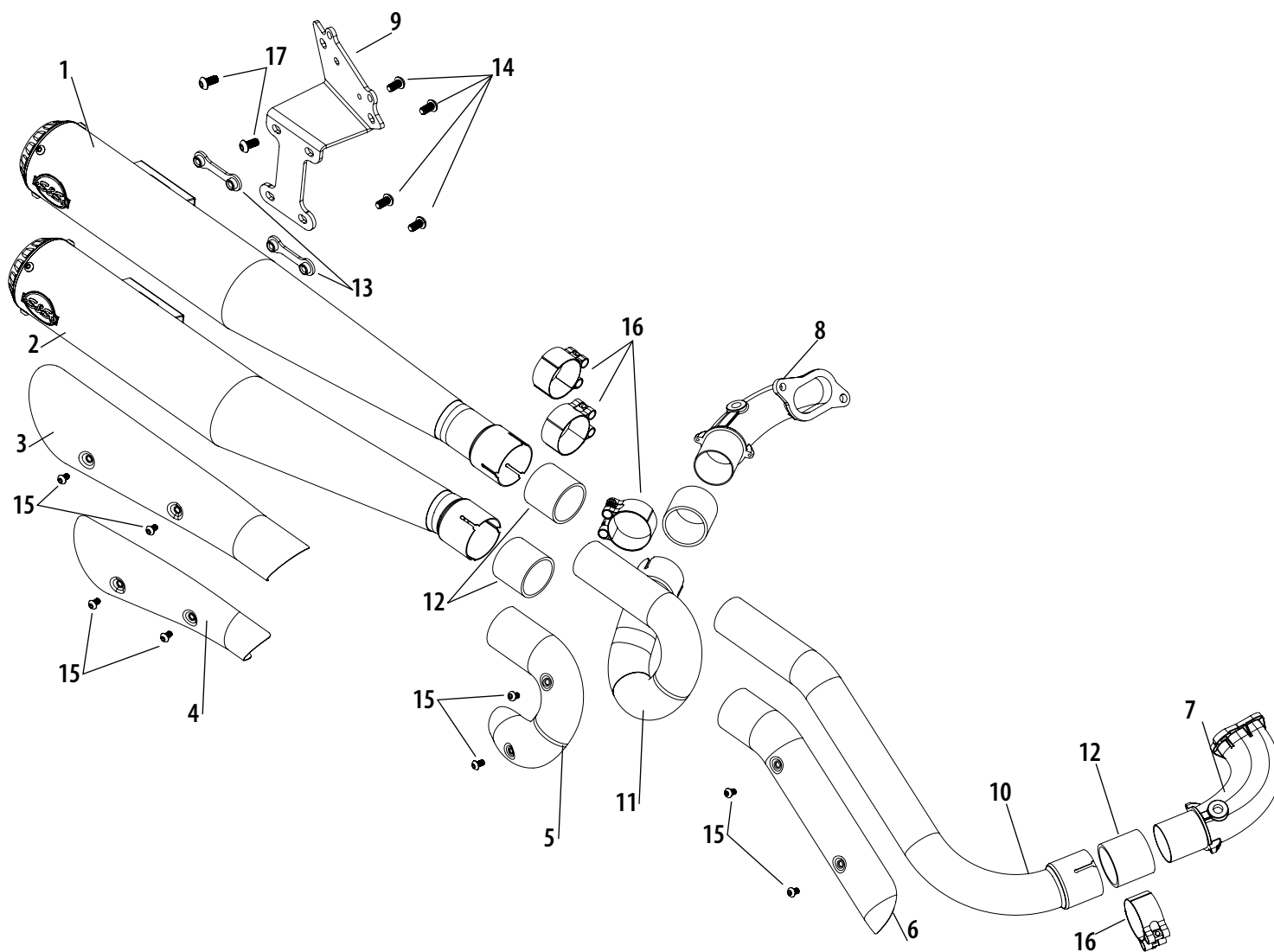

1. Muffler, Assembly, Top, Gasket Compatible, 2 into 2, 2019-'22 FTR1200 Indian"	551-1165B
2. Muffler, Assembly, Bottom, Gasket Compatible, 2 into 2, 2019-'22 FTR1200 Indian"	551-1166B
3. Heat Shield, Top, Muffler, 2 into 2, Stainless Steel, FTR1200 Indian"	551-1107
4. Heat Shield, Bottom, Muffler, 2 into 2, Stainless Steel, FTR1200 Indian"	551-1109
5. Heat Shield, Rear, 2 into 2, Stainless Steel, FTR1200 Indian"	551-1111
6. Heat Shield, Front, 2 into 2, Stainless Steel, FTR1200 Indian"	551-1113
7. Adapter, Front, Pipe, Exhaust, Stainless Steel, FTR1200 Indian"	551-1068
8. Adapter, Rear, Pipe, Exhaust, Stainless Steel, FTR1200 Indian"	551-1069
9. Bracket, Mounting, Muffler, 2 into 2, Powdercoated, Black, FTR1200 Indian"	551-1114
10. Header, Front, 2 into 2, Gasket Compatible, Weldment, Stainless Steel, FTR1200 Indian"	551-1119
11. Header, Rear, 2 into 2, Gasket Compatible, Weldment, Stainless Steel, FTR1200 Indian"	551-1122
12. Gasket, Muffler	551-1129
13. Plate, Nut, 5/16-18 x 2", Clear, Zinc	551-0469
14. Screw, BHC, High Temp Lock Patch, 5/16-18 x 5/8", Stainless Steel	500-1091
15. Screw, BHC, High Temp Lock Patch, M6 x 1 x 10mm, Stainless Steel	500-1090
16. Clamp, Band Style, 52-55mm	551-1181
17. Screw, BHC, M8 x 16mm, Stainless Steel	500-1189

Thunderstroke® III Models

Air Cleaner Kit Replacement Parts

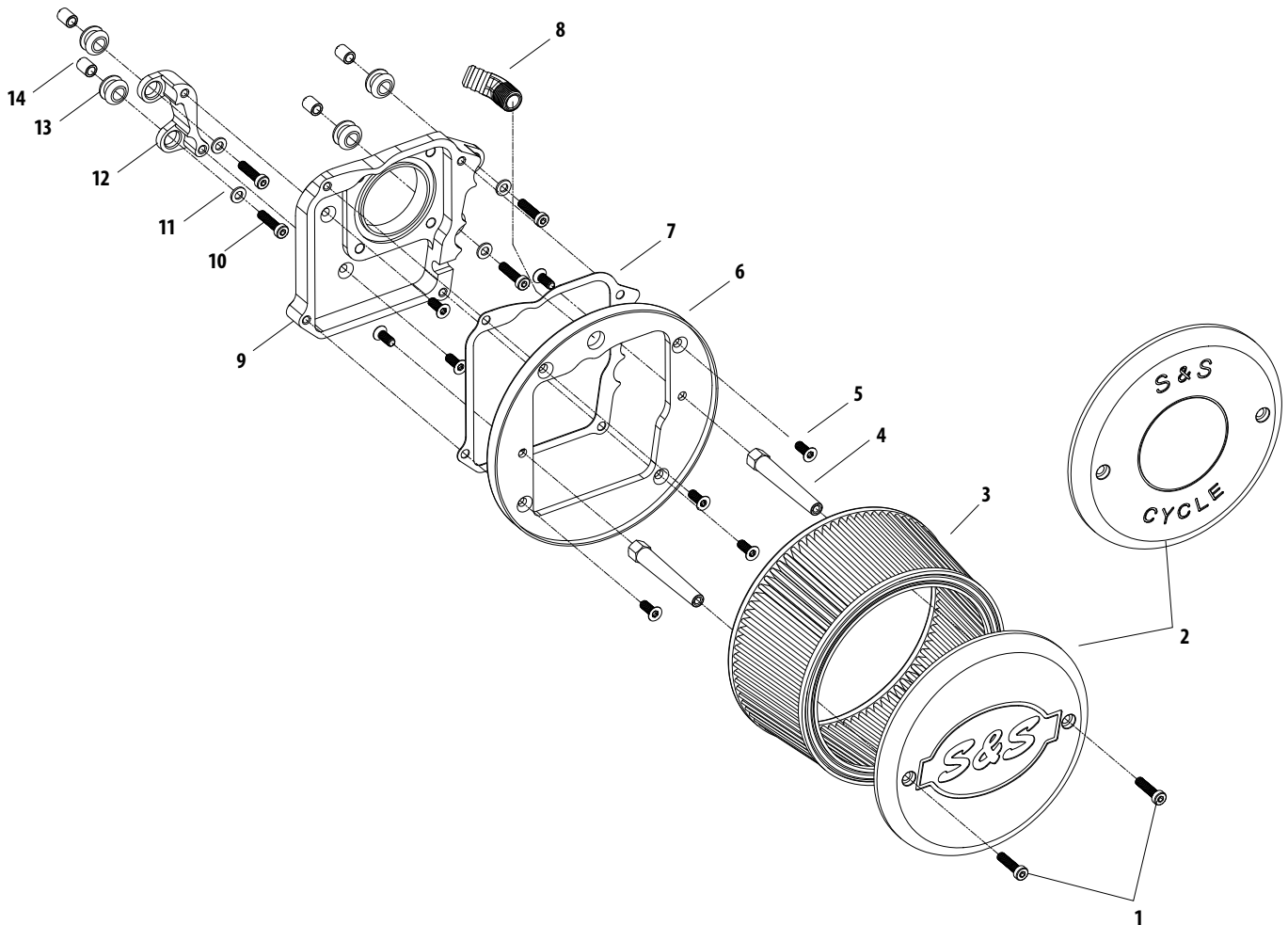

- | | |
|----------------------------------------------------|----------|
| 1. Screw, SHC Low Profile, 25mm, M6 x 1, Chrome | N/A |
| 2. Cover, Air Cleaner | |
| S&S Logo | 170-0242 |
| S&S Nostalgic Script | 170-0239 |
| 3. Filter, Air, Tapered, Standard Pleated Cotton | 170-0228 |
| 4. Standoff, Air Filter | 170-0232 |
| 5. Screw, SHC, Flat, 16mm, M6 x 1, Zinc | 500-0291 |
| 6. Backplate, Air Filter Element | 170-0230 |
| 7. Gasket, Backplate | 170-0233 |
| 8. Fitting, 45°, 3/8" NPT x 5/8" Barb, Zinc Plated | 500-0267 |
| 9. Backplate, Throttle Body | 170-0229 |
| 10. Screw, SHC Low Profile, 25mm, M6 x 1, Zinc | 500-0271 |
| 11. Washer, Flat, M6, Zinc | 500-0272 |
| 12. Bracket, Backplate | 170-0236 |
| 13. Grommet, Backplate, Rubber | 500-0269 |
| 14. Spacer, Zinc | 500-0270 |



Grand National® Slip-On Replacement Parts

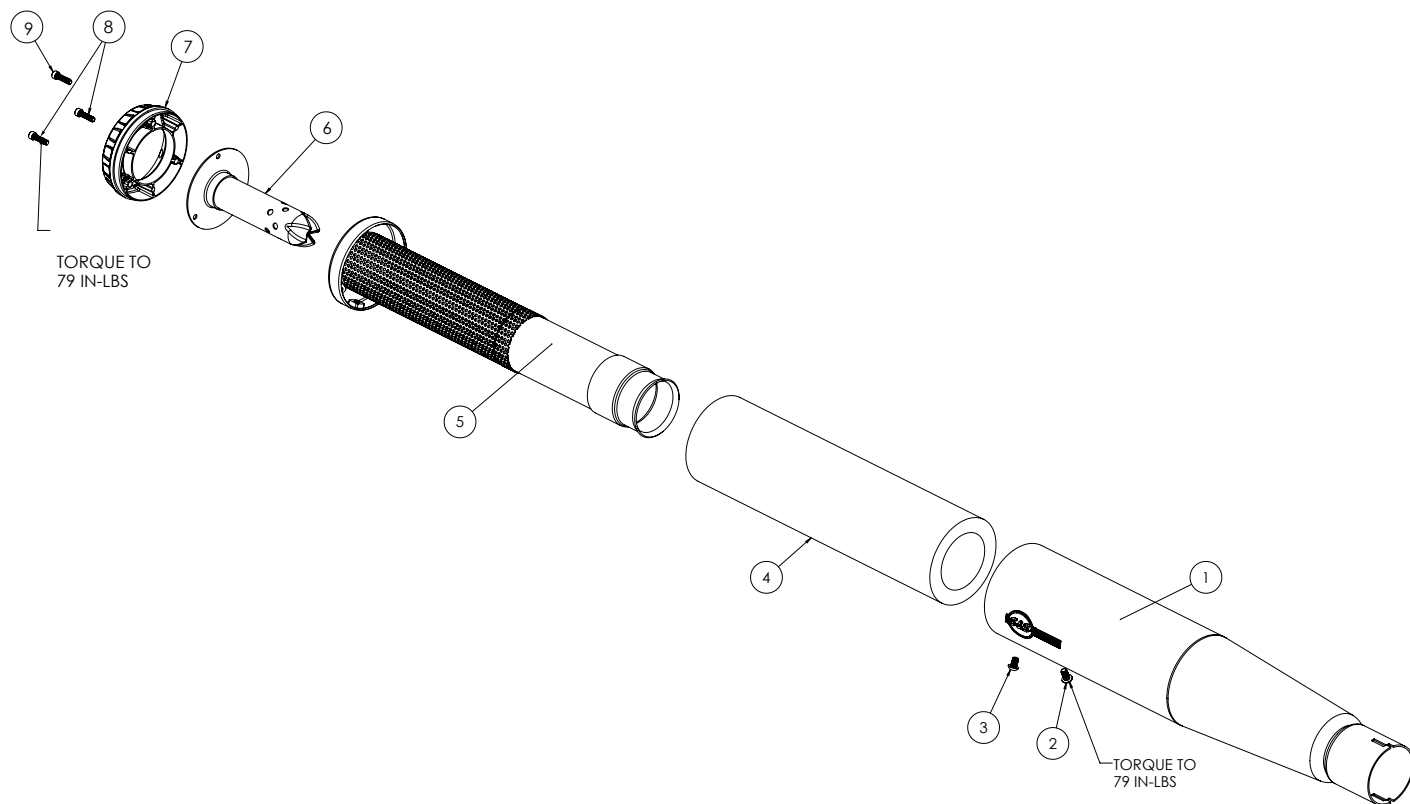

- 1. Shell, Muffler, 2 Into 1, Outside Process, Chrome, Indian® Scout®551-1024A
- 2. Screw, S&S™ Tamperproof, BHC, 1/4-20 x 1/2", High Temp Lock Patch, Stainless Steel 500-1075
- 3. Screw, BHC, High Temp Lock Patch, 1/4-20 x 3/8", Stainless Steel..... 500-0441500-0441
- 4. Insulation, Muffler, Pillow Pack, Ø3.8 Od X 14"..... 551-0819
- 5. Baffle, Assembly, 2020 Indian® Scout® 551-1026
- 6. Baffle, Assembly, Muffler, 10 X 1/4" Hole, Sae J2825, 1.375"..... 551-0838
- 7. Cap, End, Muffler, Grand National, Powdercoated, 4", Black..... 551-0291\$50.95551-0291
- 8. Screw, SHC, High Temp Lock Patch, 10-32 x 3/4", Stainless Steel..... 500-0569500-0569
- 9. Screw, S&S™ Tamperproof, SHC, 10-32 x 3/4", High Temp Lock Patch, Stainless Steel..... 500-1073500-1073

Grand National 2:1 Exhaust System Replacement Parts

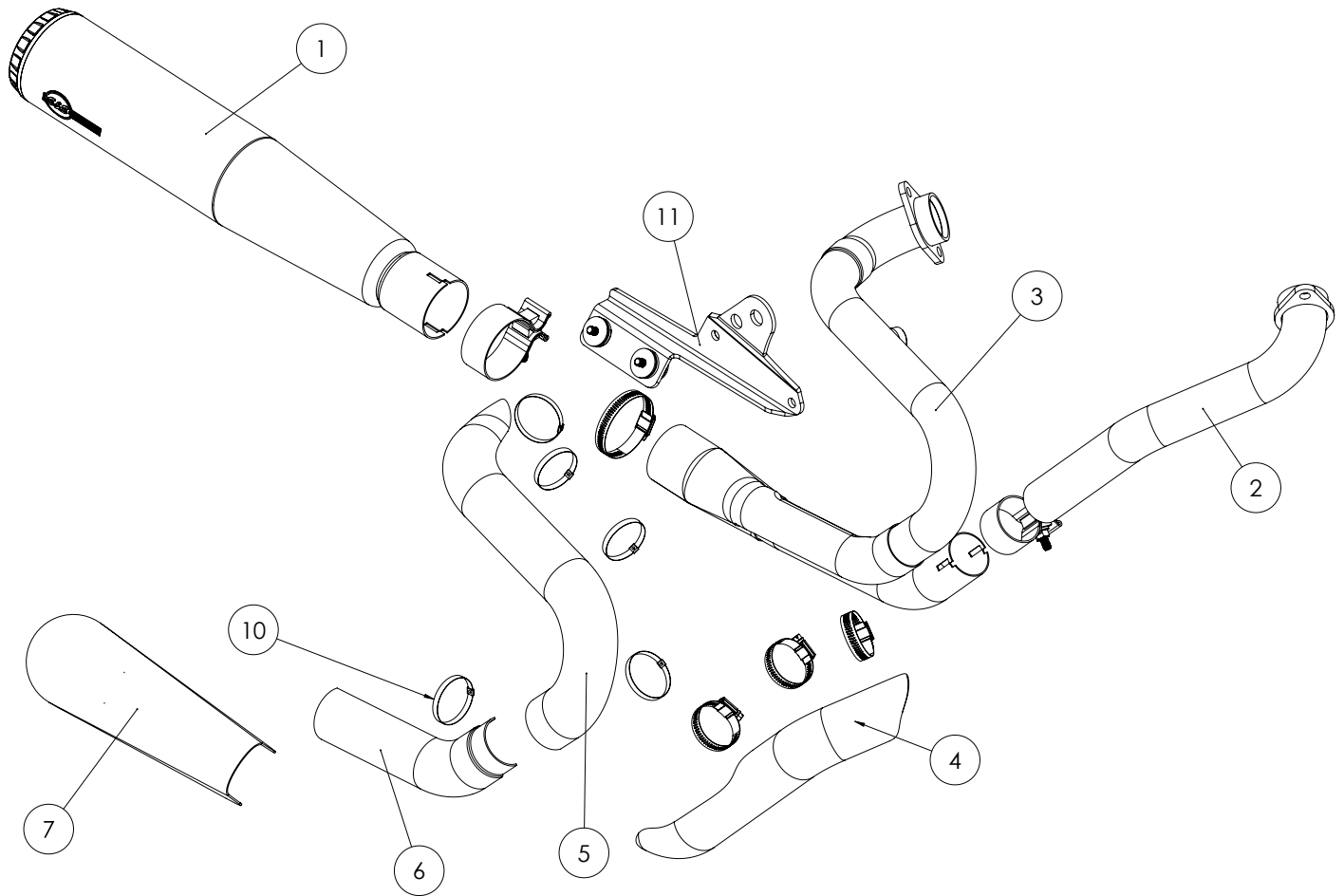

⑨ 2208030A HARDWARE KIT

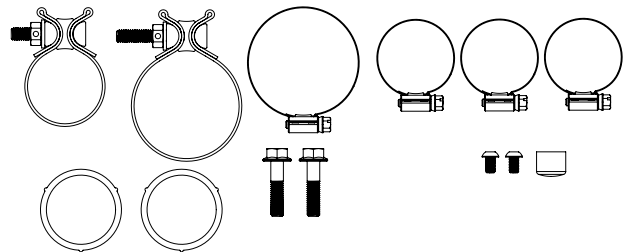

1. Muffler, Assembly, 49 State, 2 into 1, 4", Black Shell, Indian® Scout®	551-0954A
2. Header, Front, 2 into 1, Stainless Steel, Indian® Scout®	551-0966
3. Header, Assembly, 2 Into 1, Weldment, Indian® Scout®	551-0952
4. Heat Shield, Front, Black, Indian® Scout®	551-0957A
5. Heat Shield, Rear, Black, Indian® Scout®	551-0959A
6. Heat Shield, Rear, Lower, Black, Indian® Scout®	551-1104A
7. Heat Shield, Collector, Black, Indian® Scout®	551-0961A
9. Hardware Kit, 2 Into 1, Indian® Scout®	2208030A
10. Clamp, Cable Tie, .25" X .015" X 10"	551-1009
11. Bracket, Mount, Muffler, Powdercoated, Black, 2 Into 1, Indian® Scout®	551-1029



S I N C E 1 9 5 8



S&S Cycle, Inc.
14025 CTY HWY G
Viola, WI 54664



608-627-1497
sscust@sscycle.com
sscycle.com